

# 24-Inch Columns

## Precision CMU

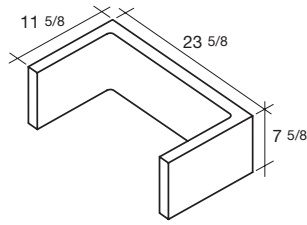

24x8x12 C-Alternate

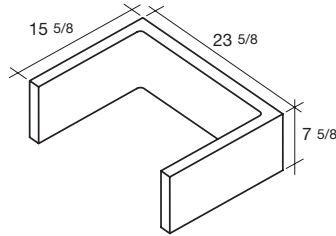

24x8x16 C-Alternate

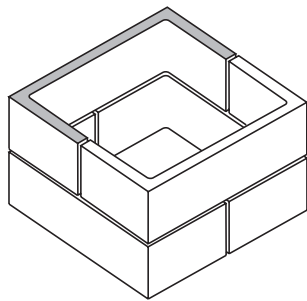

24x8x12 Alternate Coursing  
Running Bond

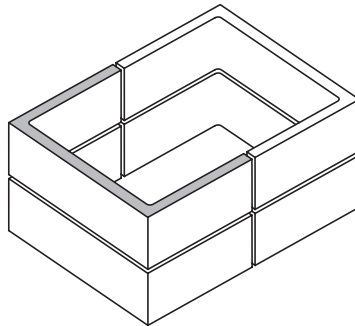

24x8x16 Coursing  
Stack Bond

### Availability

**Special order only.** Available in any of our integral color options.

### Standards

Concrete masonry units manufactured by Angelus Block Co., Inc. meet ASTM C90 Standard Specification for Loadbearing Concrete Masonry Units.

### Fire Rating

Solid grouted walls 8-in wide and greater are rated at 4 hours, per CBC Table 721.1(2). For partially grouted walls, depending on the specified weight classification, 8-inch wide units are 1 hour to 2 hours, and 12-inch wide units are 2 hours to 3 hours.

### Sustainable Features

- This product is included in Type III Environmental Product Declarations for Angelus Block Concrete Masonry Units, specific to location and mix designs, and in one of six *Health Product Declarations*, as applicable for its weight classification.
- Contributes to green rating systems calculations, including Regional Materials, EPDs, and Material Ingredient Reporting.
- Angelus Block CMU help facilitate and support many more strategies and credits, including Optimize Energy Performance, Construction Waste Management, and several within Indoor Environmental Quality. Angelus Block CMU contain no VOCs.

See *Sustainable & Resilient Design: Angelus Block Products' Application to Rating Systems and Code* for detailed information. A copy is available from your representative, or as a download at [www.AngelusBlock.com](http://www.AngelusBlock.com).

Shell and web configurations as shown are representational only, and actual configurations may differ.

Corporate Office & Plants:  
11374 Tuxford St.  
Sun Valley, CA 91352  
(818) 767-8576

Orange, CA  
Fontana, CA  
Gardena, CA

Oxnard, CA  
Indio, CA  
Bakersfield, CA

[www.AngelusBlock.com](http://www.AngelusBlock.com)

[info@AngelusBlock.com](mailto:info@AngelusBlock.com)

**CarbonKind**™  
by Angelus Block

This is a low impact CarbonKind™ product which substantially reduces CO<sub>2</sub>e. Learn more at Angelus Block/CarbonKind.



**WARNING:** This product can expose you to Silica, crystalline (airborne particles of respirable size) which is known to the State of California to cause cancer. For more information, go to [www.P65Warnings.ca.gov](http://www.P65Warnings.ca.gov).